

HOSONIC ELECTRONIC CO., LTD.

CRYSTAL UNIT SPECIFICATIONS

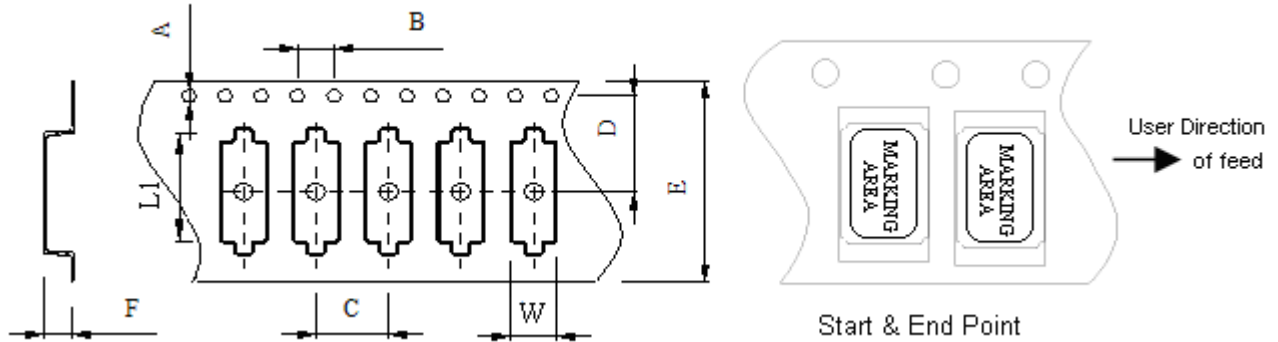

Package (units : mm)



Model	A	B	C	D	E	F	L1	W
HC-49SMA	Φ 1.50	4.0	12	11.5	24±0.3	4.35	15.0	5.0
HC-49SMB	Φ 1.50	4.0	12	11.5	24±0.3	3.5	15.0	5.0

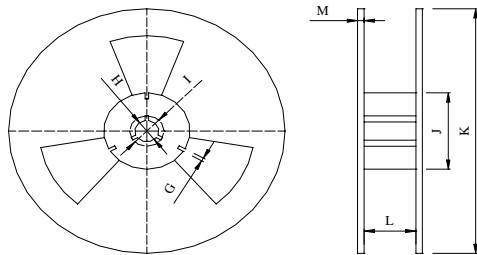

Model	G	H	I	J	K	L	M
HC-49SMA	2.4±0.1	Φ 13.5	20±0.1	100±0.1	330±0.1	25.5±0.1	2.1±0.1
HC-49SMB	2.4±0.1	Φ 13.5	20±0.1	100±0.1	330±0.1	25.5±0.1	2.1±0.1

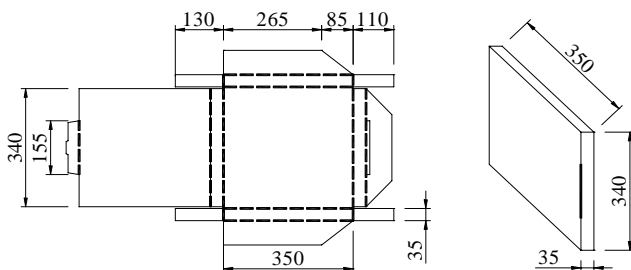

Notes:
 1 units: mm
 2 --- 折痕

1 REEL = 1 INNER BOX

*Specifications are subject to change without notice.

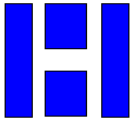

Package (units : mm)

(Continued)

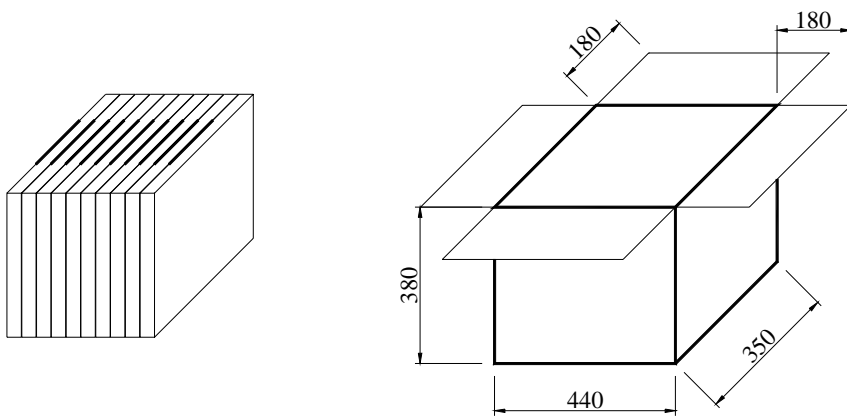

10 INNER BOX = 1 OUTER BOX

- 10,000 pcs = 1 OUTER BOX